



THE YAMAHA ADVANTAGE™ RECORDER PLUS

Musicianship from Day One™
by Sandy Feldstein and Larry Clark

Welcome to The Yamaha Advantage™ Recorder Plus

This method will teach you to play the recorder by having fun singing and playing your favorite songs. After learning to play the recorder, you may wish to learn to play a band or orchestral instrument. To help you make your choice, The Yamaha Advantage™ Recorder Plus Method includes information about many instruments.

The optional CD accompaniment for this book is recorded by a great band. The CD will also give you an example of how your instrument should sound, as well as the other instruments you might like to play. It will also provide hours of enjoyable play-along experiences. (CD available separately.)

Have a great time making music.

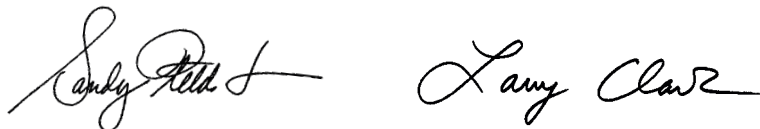

The instruments of today's band and orchestra are divided into four INSTRUMENT FAMILIES. The WOODWIND FAMILY (not all are made of wood), the BRASS FAMILY, the PERCUSSION FAMILY and the STRING FAMILY. Throughout this book we will take a closer look at some instruments from each of the families.

ADVANTAGE • PRACTICE

Date	Teacher · Assignments/Goals	Student · Notes/Questions	Mon.	Tues.	Wed.	Thurs.	Fri.	Sat.	Sun.	Approval
										

CARL FISCHER®
65 Bleecker Street, New York, NY 10012

Copyright © 2003 by PlayinTime Productions™, Inc.
International Copyright Secured.

All rights reserved including performing rights.

WARNING! this publication is protected by Copyright law. To photocopy or reproduce by any method is an infringement of the Copyright law. Anyone who reproduces copyrighted matter is subject to substantial penalties and assessments for each infringement.

Printed in the U.S.A.



LAYOUT & ENGRAVING:
Mark Ralston & Musical/Arts Consultants Inc

YRS1

YAMAHA®
Is a registered trademark of Yamaha Corporation of America

ISBN 0-8258-xxxx-x

Introduction to Music Theory

STAFF

Music is written on a five line staff. Between each line there is a space.

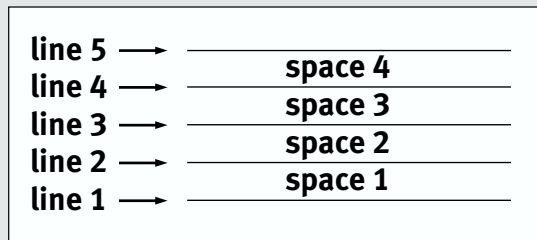

At the beginning of each staff there is a clef. The treble clef encircles the second line which is the note G and is sometimes called the G clef.

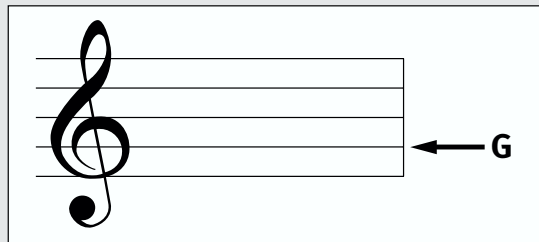

MEASURE AND BAR LINES

Music is divided into measures by bar lines. Double bar lines end a piece of music.

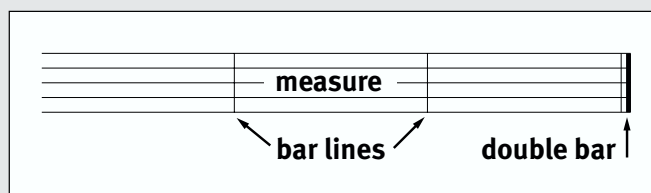

TIME SIGNATURE

At the beginning of a piece of music there is a time signature. It tells you how many beats are in each measure and what note gets one beat.

$\frac{4}{4}$ = four beats in each measure
 $\frac{4}{4}$ = a quarter note gets one beat

a half note or rest gets two beats

a whole note or rest gets four beats

Getting Started



RIGHT HAND

Hold the bottom or bell of the recorder with your right hand.

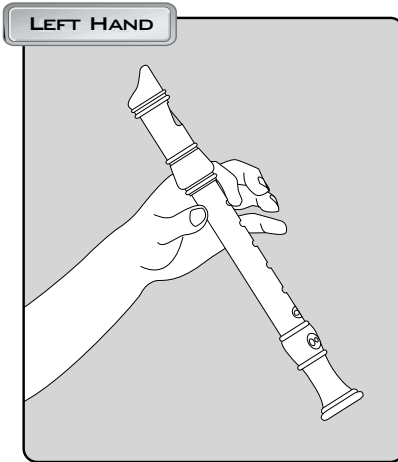

LEFT HAND

Cover the top hole in the back with your thumb and the first (top) hole on the front with your first finger.



PLAYING

Put the tip of the mouthpiece in your mouth and lightly blow. To start each note say "Tu".

You are now playing your first note:

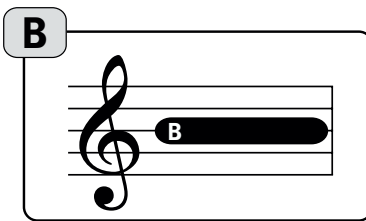

NOTES

Your First Note

1

Half the Time

2

The First Quarter

3

NOTES

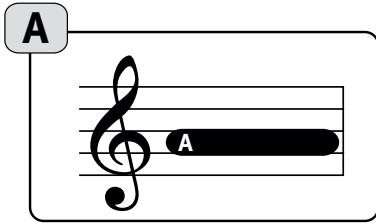

To play **A**, keep your thumb and first finger down.
Cover the second hole in the front with your second finger.

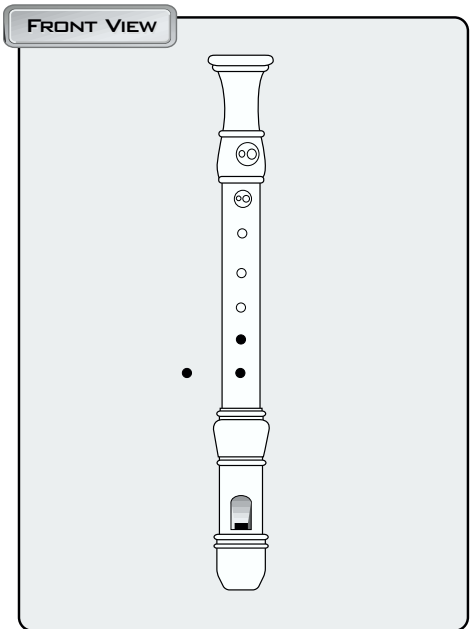
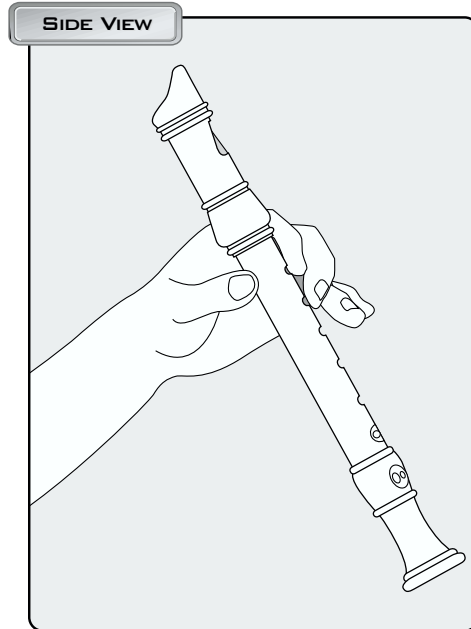

Your Second Note

4

The Second Half

5

The Second Quarter

6

NOTES

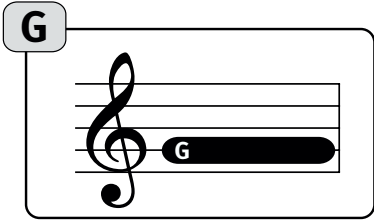

To play **G**, keep your thumb and first two fingers down. Cover the third hole in the front with your third finger.

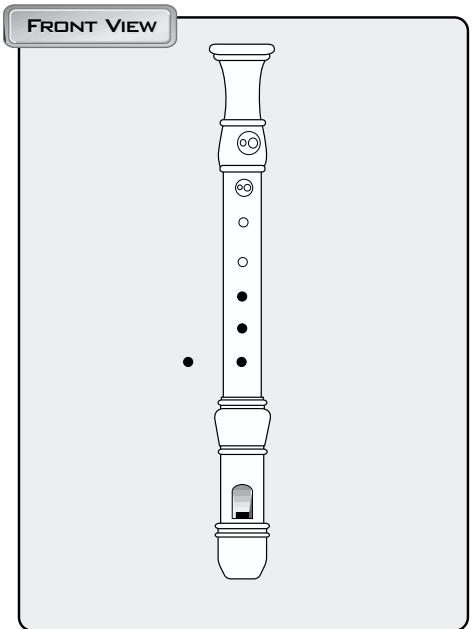
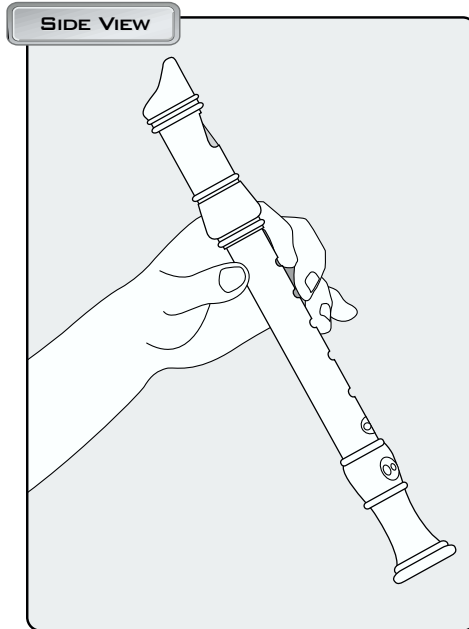

THEORY

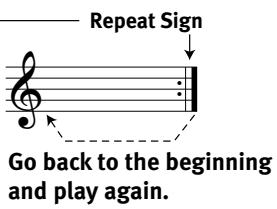

7

Your Third Note

Play Rest Play Rest Repeat sign

8

The Third Half

Play Rest Play Rest

9

The Third Quarter

Play Rest Play Rest

All Three Notes

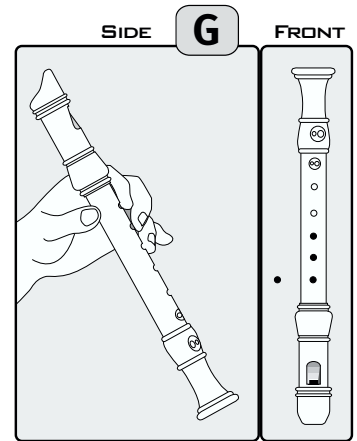
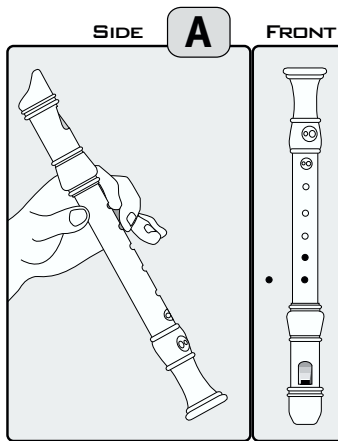
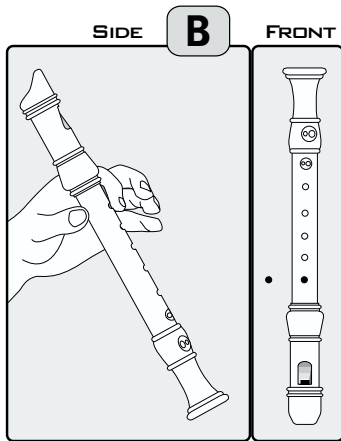

When moving from **B** to **A** to **G**, your second finger covers the second hole and then your third finger covers the third hole.

Moving Down

10

Listen to the sound. When you put your fingers down, the sound goes down or gets lower.

When moving from **G** to **A** to **B**, your third finger comes up and opens the third hole and then your second finger comes up and opens the second hole.

Stepping Back Up





11

Listen to the sound. When you lift your fingers up, the sound goes up or gets higher.

Down and Up

12

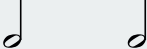
▼ RHYTHM

Shape Note	Music Note	Note Name
	= 	= whole note
	= 	= half note
 1 2 3 4	=  1 2 3 4	= quarter note

Play the beginning of these familiar songs written with shape notes followed by music notation.

Hot Cross Buns

13

1 2 3 4 1 2 3 4 1 2 3 4 1 2 3 4
Hot Cross Buns. Hot Cross Buns.

Count: 1 2 3 4 1 2 3 4 1 2 3 4 1 2 3 4
Hot Cross Buns. Hot Cross Buns.

Merrily We Roll Along

14

1 2 3 4 1 2 3 4 1 2 3 4 1 2 3 4
Mer - ri - ly we roll a - long, roll a - long, roll a - long.

Count: 1 2 3 4 1 2 3 4 1 2 3 4 1 2 3 4
Mer - ri - ly we roll a - long, roll a - long, roll a - long.

ADVANTAGE

PERFORMANCE

Hot Cross Buns

Traditional

15

Musical notation for the first line of 'Hot Cross Buns' in 4/4 time. The notes are B4, A4, G4, B4, A4, G4.

Hot Cross Buns. Hot Cross Buns.

Musical notation for the second line of 'Hot Cross Buns' in 4/4 time. The notes are G4, G4, G4, G4, A4, A4, A4, A4, B4, A4, G4.

One a pen - ny two a pen - ny Hot Cross Buns.

Merrily We Roll Along

Traditional

16

Musical notation for the first line of 'Merrily We Roll Along' in 4/4 time. The notes are B4, A4, G4, A4, B4, B4, B4, A4, A4, A4, B4, B4, B4.

Mer - ri - ly we roll a - long, roll a - long, roll a - long.

Musical notation for the second line of 'Merrily We Roll Along' in 4/4 time. The notes are B4, A4, G4, A4, B4, B4, B4, A4, A4, B4, A4, G4.

Mer - ri - ly we roll a - long, o'er the deep blue sea.

Au Clair De La Lune

French Folk Song

17

Musical notation for the first line of 'Au Clair De La Lune' in 4/4 time. The notes are G4, G4, G4, A4, B4, A4, G4, B4, A4, A4, G4.

Sing this lit - tle French song, "Bon - jour" means hel - lo.

Musical notation for the second line of 'Au Clair De La Lune' in 4/4 time. The notes are G4, G4, G4, A4, B4, A4, G4, B4, A4, A4, G4.

Sing this lit - tle French song, "Bon - soir" means good - bye.

ADVANTAGE
THEORY

Fingering

Name the note and color the holes that are covered to play the notes indicated.

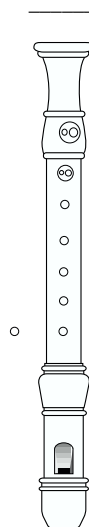
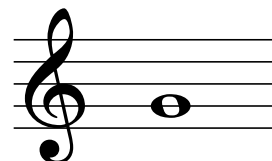
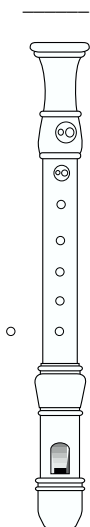
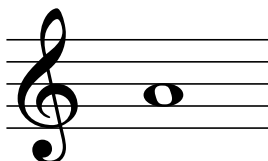
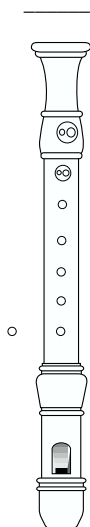
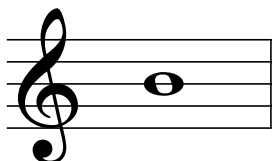

Matching Game

Draw a line to connect the symbol with its name.



Whole Note

Quarter Note

Half Note

More Matching

Draw a line to connect the musical example to its name.
Music is divided into these.



Double bar line

This tells you there are four beats in each measure and a quarter note gets one beat.

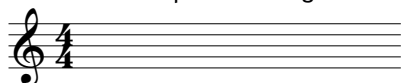

Measures

This shows the end of the music.

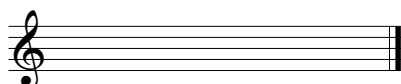

Time Signature

NOTES

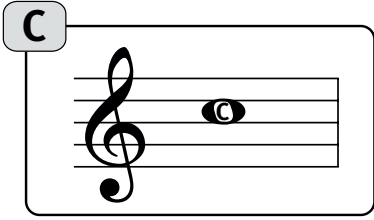

To play C, keep your thumb on the hole in the back and cover the second hole on the front with your second finger.

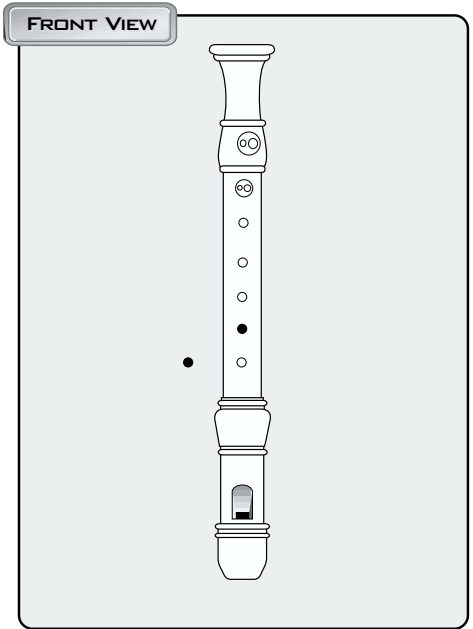
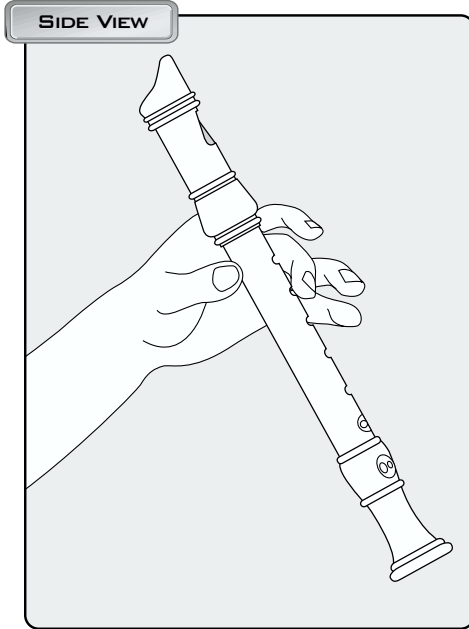

Scale Song

18

Musical staff for Scale Song in 4/4 time, starting on C. Notes: Do (quarter), Ti (quarter), La (quarter), Sol (quarter), Down (quarter), the (quarter), scale (quarter), and (quarter), back (quarter), a - gain. (quarter).

Down by the Station

Traditional

19

Musical staff for Down by the Station in 4/4 time. Lyrics: Down by the sta - tion ear - ly in the mor - ning. See the sta - tion mas - ter toot toot off we go.

ADVANTAGE COMPOSING

Composing Fun

Finish this song by adding a friend's name in measures one and two. To complete the melody, add one note that you have learned in measures four and eight. Add your name as the composer.

Friendship Song

By _____

20

Musical staff for Friendship Song in 4/4 time. Lyrics: Hel - lo __ - __, hel - lo __ - __, I'm your friend. Friend - ship, friend - ship our great friend - ship will not end.

NOTES

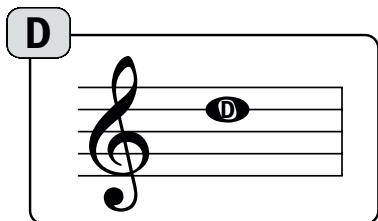

To play **D**, lift your thumb off the hole in the back and cover the second hole on the front with your second finger.

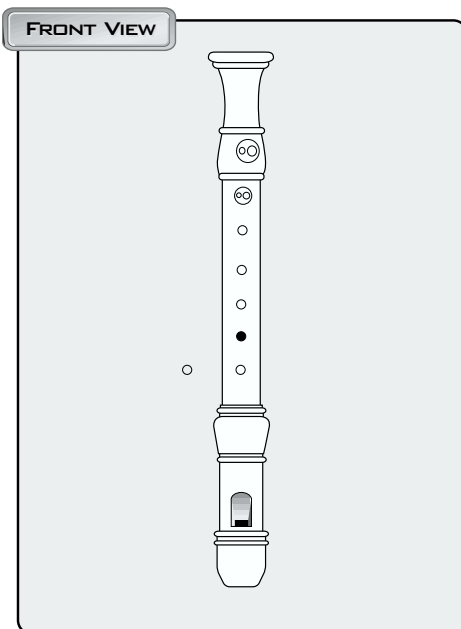
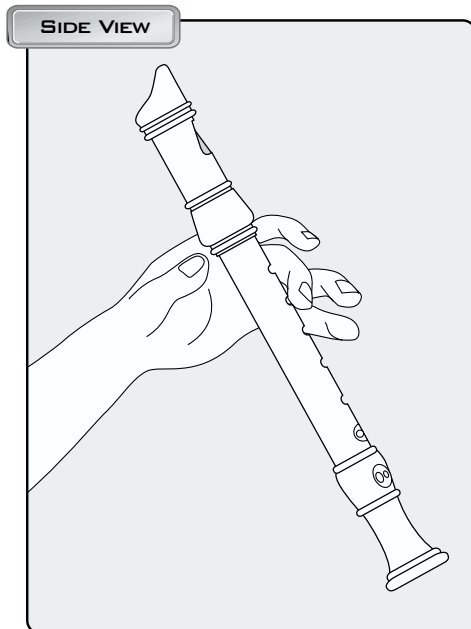

A Minor Mood

21

D

Oats and Beans and Barley Grow

American Folk Song

22

ADVANTAGE RHYTHM

Rap 'n' Rhythm

Add the bar lines, clap the rhythm then sing the rap.

23

Everyone:

Girls: Boys: Girls: Boys:

Go Tell Aunt Rhody

Traditional

24

Go tell Aunt Rhody. Go tell Aunt Rhody.

Go tell Aunt Rhody, the old gray goose is dead.

Good King Wenceslas

Traditional Carol

25

Good King Wenceslas looked out, On the Feast of Stephen,

When the snow lay round about, Deep and crisp and even.

Ode to Joy

Ludwig van Beethoven

26

When we sing this melody, our hearts are filled with joyfulness.

Sing it loud and sing it strong, this melody by Beethoven.

Lightly Row

German Folk Song

27

Light - ly row, light - ly row, o'er the shin - ing waves we go;
 Smooth - ly glide. smooth - ly glide, on the si - lent tide.
 Let the wind and wa - ters be min - gled with our mel - o - dy,
 Sing and float, sing and float, in our lit - tle boat.



ADVANTAGE

MEET THE INSTRUMENTS

28 The **FLUTE**, which is made of metal, is a member of the woodwind family and plays the high notes in band and orchestra music.

The flute is played by blowing across the open hole in the mouthpiece, much like you might blow across the top of a bottle to make a sound.

The air that goes into the instrument vibrates to produce the flute sound.

To play sounds (notes) that are higher or lower, you release or depress the keys.

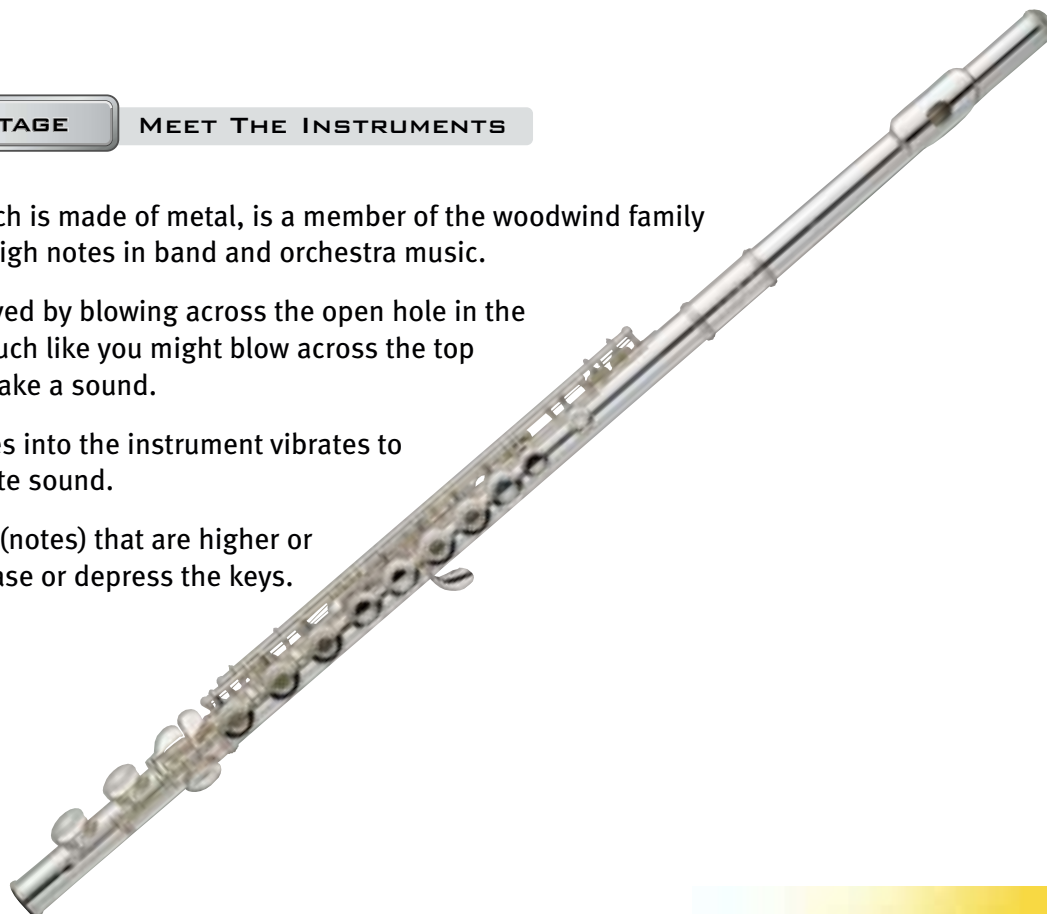
www.yamahaadvantage.com

RHYTHM

Eighth Notes

quarter rest

Aura Lee

Folk Song

29

As a black - bird in the Spring, 'Neath the wil - low tree.
 Joy - ous - ly I heard him sing, of his Au - ra Lee.

Jingle Bells

James Pierpont

30

Jin - gle bells, Jin - gle bells, Jin - gle all the way!
 Oh what fun it is to ride a one horse o - pen sleigh! Hey!
 Jin - gle bells, Jin - gle bells, Jin - gle all the way!
 Oh what fun it is to ride a one horse o - pen sleigh!

Count the beats and clap the rhythm, then sing the rhythm

31

1 & 2 & 3 & 4 & 1 & 2 & 3 4 1 & 2 3 & 4 1 & 2 & 3 4 Quarter Rest

▼ RHYTHM

■ half rest

▼ MUSICIANSHIP

Tempo: Slow, Moderately

Jingle In Eighths

Slow

James Pierpont

32

Jin - gle bells, Jin - gle bells, Jin - gle all the way! Oh what fun it is to ride a one horse o - pen sleigh! Hey!

Jin - glebells, Jin - gle bells, Jin - gle all the way! Oh what fun it is to ride a one horse o - pen sleigh!

Compare this version of *Jingle Bells* to the one on pg. 14.

Over My Head

Moderately

African-American Spiritual

33

1 2 3 & 4
O - ver my head, I hear mu - sic in the air.

Yes o - ver my head, I hear mu - sic in the air.

O - ver my head, I hear mu - sic in the air.

There must be a heav - en some - where. Yeah!

THEORY

3 - three beats in each measure
4 - quarter note gets one beat

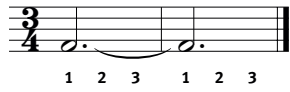
Tie 

RHYTHM

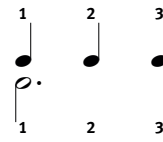
Dotted Half Note 

Barcarolle

Jacques Offenbach

Moderately

34

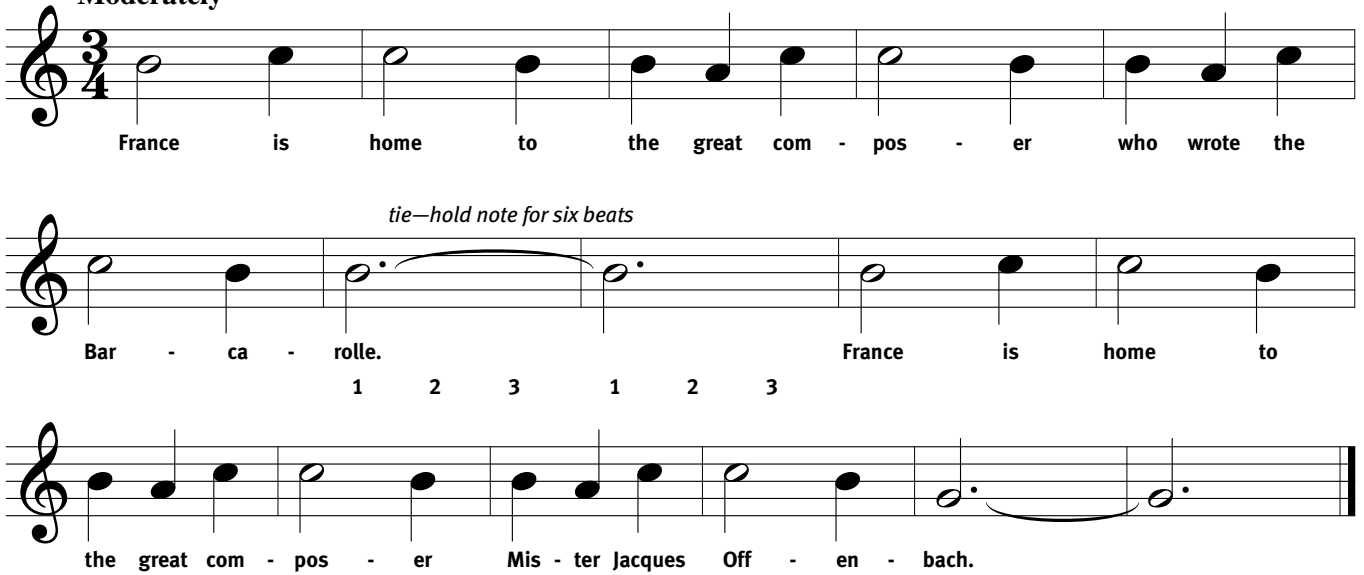

France is home to the great com - pos - er who wrote the
 Bar - ca - rolle. France is home to
 the great com - pos - er Mis - ter Jacques Off - en - bach.

Solve the riddle and fill in the name of the song.

The _____ Song

Sandy Feldstein & Larry Clark

Moderately

35

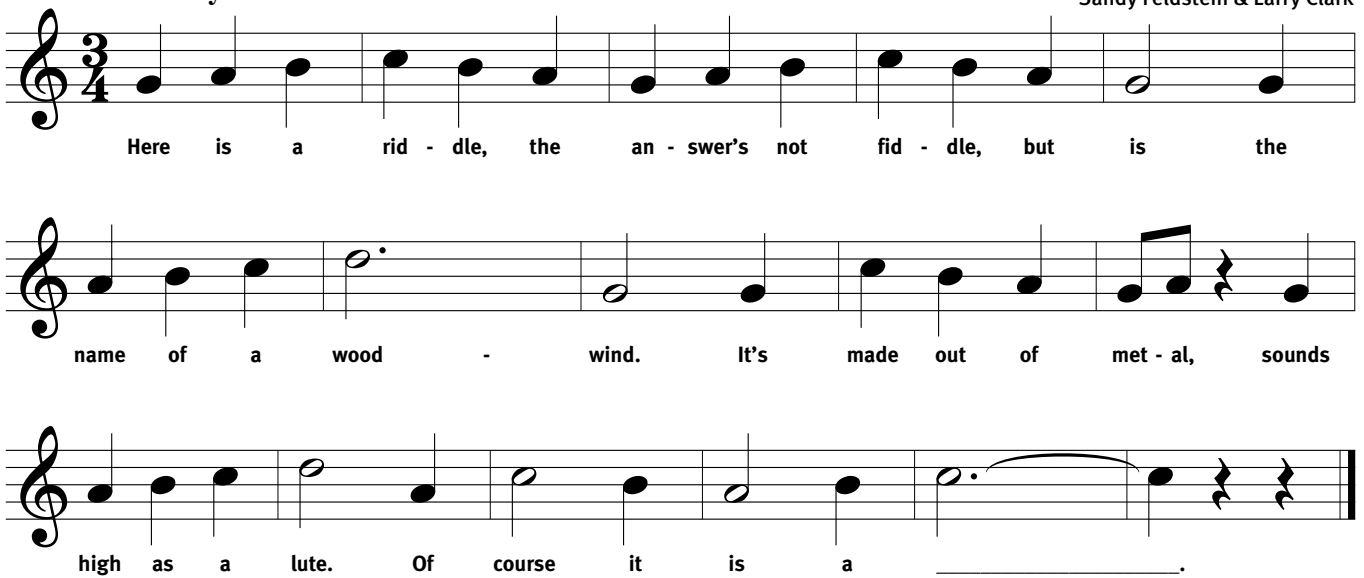

Here is a rid - dle, the an - swer's not fid - dle, but is the
 name of a wood - wind. It's made out of met - al, sounds
 high as a lute. Of course it is a _____.

Love Somebody

Moderately

Traditional

36

Love some - bod - y! 'Deed I do! Love some - bod - y! Now guess who?
 Love some - bod - y! Have you guessed? You're the one that I love best!

Fill in the name of your favorite day of the week.
 Write your name as the composer.

The Days of the Week

Moderately

By _____

37

Mon - day, Tues - day, Wednes - day, Thurs - day, Fri - day, Sat - ur - day, Sun - day.
 All the days are fun, but I like _____ best.



ADVANTAGE

MEET THE INSTRUMENTS

38

The **CLARINET**, which is made of wood, is a member of the woodwind family. The clarinet is played by blowing across a reed made of wood (cane), which is attached to the mouthpiece. The reed vibrates and sends the vibrations through the instrument to produce the clarinet sound. To play sounds (notes) that are higher or lower, you release or depress the keys.



www.yamahaadvantage.com

NOTES

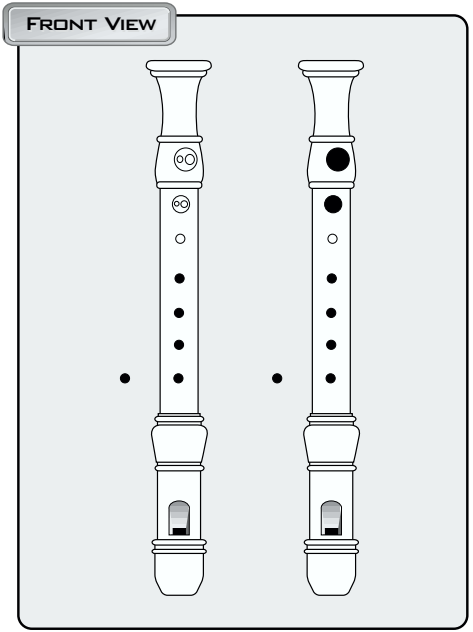
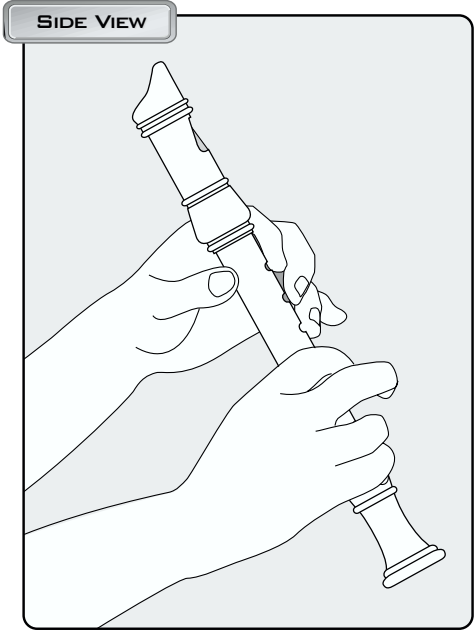
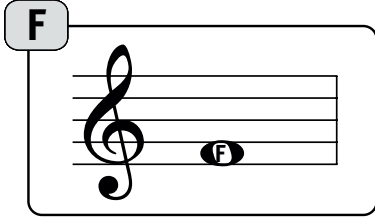

To play F, you add the right hand. There are two fingerings for F. Just adding the first finger of the right hand is okay; but if you also add your third and fourth fingers, the note will sound more in tune.

Skipping to and from F requires movement of fingers in both hands. Practice this exercise slowly before playing *Goodbye, Old Paint*.

39

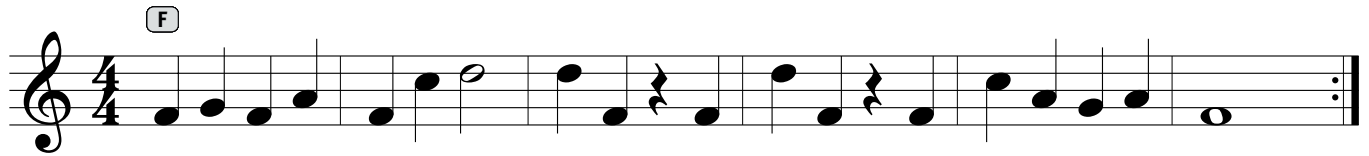

Goodbye, Old Paint

40

Slow American Folk Song

Good - bye, Old Paint, I'm leav - in' Chey - enne. Good -

bye, Old Paint, I'm leav - in' Chey - enne. I'm leav - in' Chey - enne. I'm

off to Mon - tan! Good - bye, Old Paint, I'm leav - in' Chey - enne.

NOTES

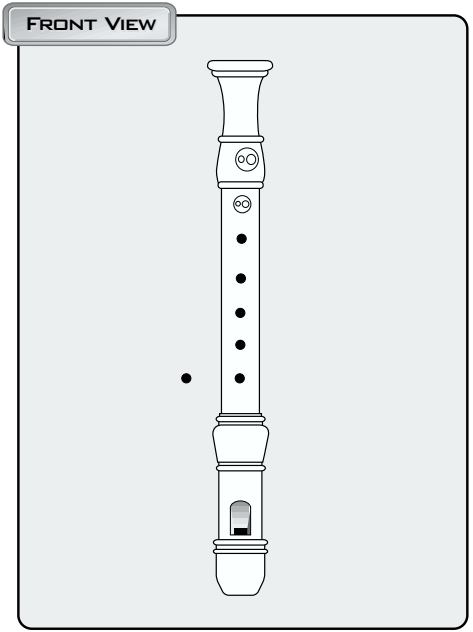
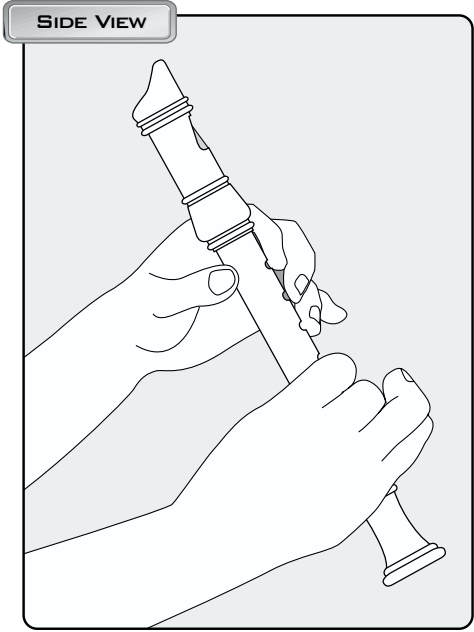
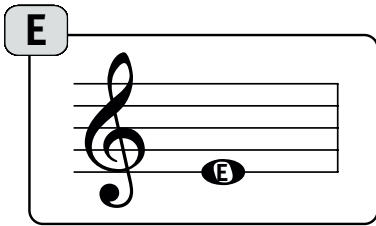

To play E, keep your left hand down and add fingers one and two of your right hand.

Be sure your fingers completely cover the holes.

41



Solve the riddle and fill in the name of the song.

The Dixieland _____

Moderately

42

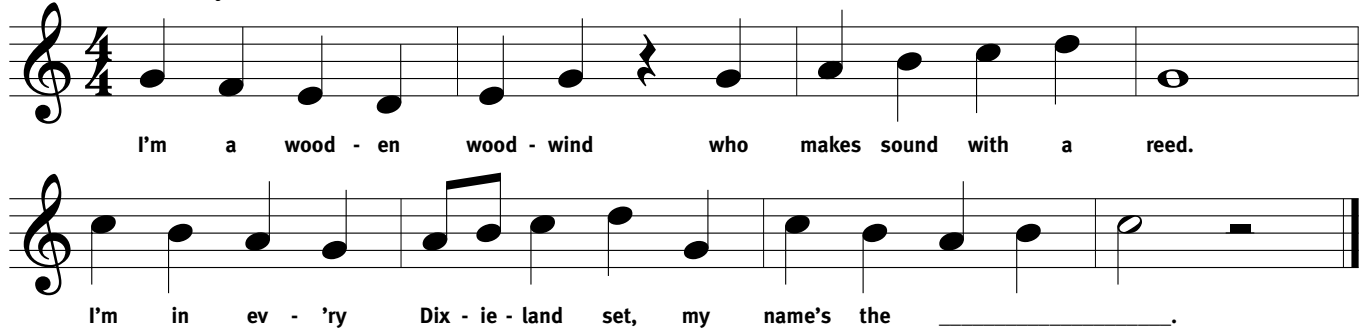

Rockin' Recorder (Duet)

Play each line separately, then play as a duet.

Sandy Feldstein & Larry Clark

Moderately

43

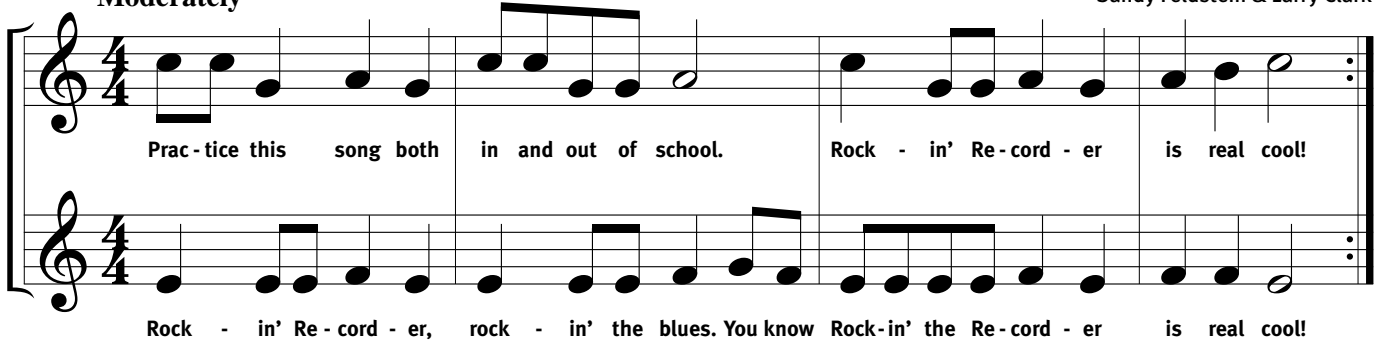

NOTES

D

To play **D**, add the third finger of your right hand.

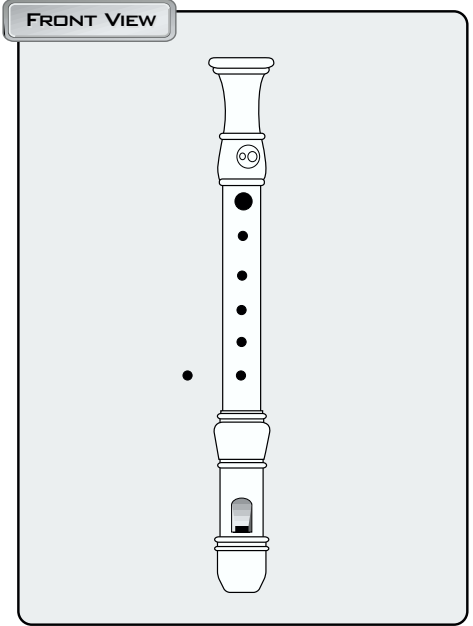
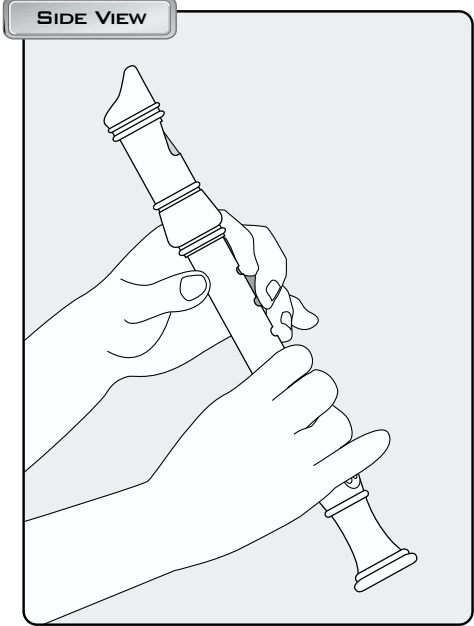

THEORY

1st and 2nd Ending

Jolly Old Saint Nicholas

Moderately

Traditional Carol

44

1. Jol - ly old Saint Ni - cho - las, lean your ear this way!
 2. Christ - mas Eve is com - ing soon; Now, you dear old man,
 Don't you tell a sin - gle soul what I'm going to say.
 whis - per what you'll bring to me, tell me if you can.

ADVANTAGE RHYTHM

Add the bar lines, write in the counts, clap, sing and play.

45

ADVANTAGE MEET THE INSTRUMENTS

46

The **SAXOPHONE**, which is made of brass, is a member of the woodwind family. Like the clarinet, the saxophone is played by blowing across a reed made of wood (cane), which is attached to the mouthpiece. The reed vibrates and sends the vibrations down through the instrument to produce the saxophone sound. To play sounds (notes) that are higher or lower, you release or depress the keys.



Lullaby

Slow

Traditional

47



Sleep ba - by sleep, sleep ba - by sleep. Your
moth-er holds you ver - y tight, she sings this lul - la - by to-night, Sleep ba - by sleep.

MUSICIANSHIP

Tempo: Fast

Solve the riddle and fill in the name of the song.

Speak the Rap.

The _____ Rap

Sandy Feldstein & Larry Clark

48

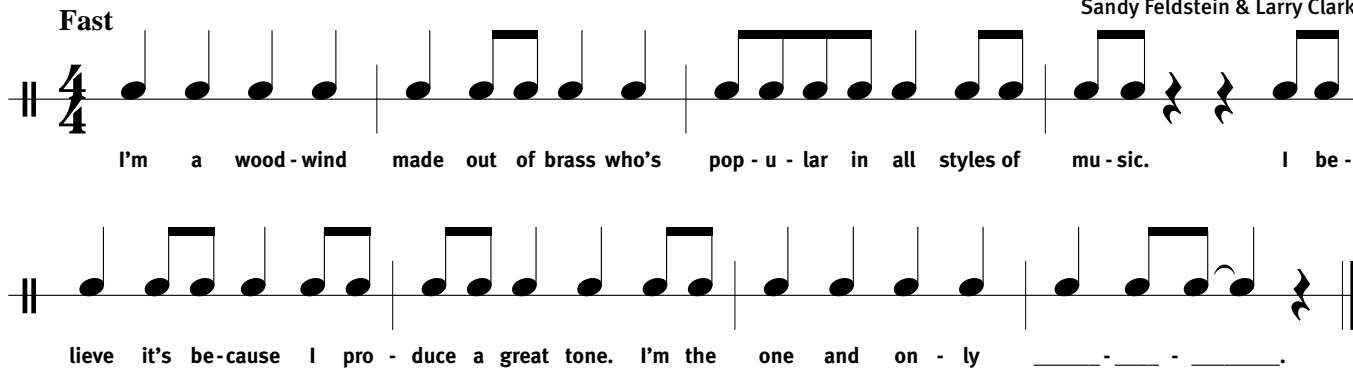

I'm a wood-wind made out of brass who's pop - u - lar in all styles of mu - sic. I be -
lieve it's be-cause I pro - duce a great tone. I'm the one and on - ly _____.

Frog Song (Round)

Moderately

Japanese Folk Song

49

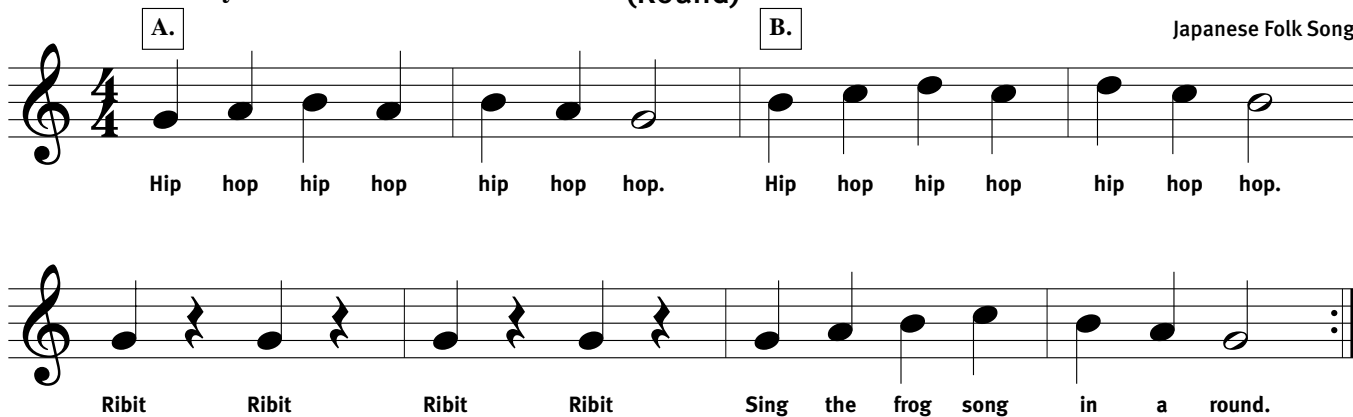

Hip hop hip hop hip hop hop. Hip hop hip hop hip hop hop.
Ribit Ribit Ribit Ribit Sing the frog song in a round.

MUSICIANSHIP

Dynamics: *f* - forte loud
p - piano soft

Beautiful Brown Eyes

American Folk Song

Moderately

1.

52

Musical notation for the first line of the song, starting with a treble clef, a 3/4 time signature, and a dynamic marking of *f*. The melody consists of quarter and eighth notes.

1. Beau - ti - ful beau - ti - ful brown eyes, smi - ling right in - to my
2. where are those beau - ti - ful brown eyes,

2.

Musical notation for the second line of the song, including a repeat sign and a dynamic marking of *f*. The melody continues with quarter and eighth notes.

heart. But now why must we be so far a - part.

THEORY

1st and 2nd endings can be more than one measure long.

ADVANTAGE

PLAY BY EAR • Good King Wenceslas

Fast

53

Musical notation for the piece 'Good King Wenceslas', starting with a treble clef, a 4/4 time signature, and a dynamic marking of *p*. The melody is simple, consisting of quarter notes.

Fill in the missing word.

Trumpet Tune

Sandy Feldstein & Larry Clark

Moderately

54

Musical notation for the first line of 'Trumpet Tune', starting with a treble clef, a 4/4 time signature, and a dynamic marking of *f*. The melody includes eighth notes and rests.

Play - ing the trum - pet is real hip, to make it sound ___ your lip.

Musical notation for the second line of 'Trumpet Tune', continuing the melody with quarter and eighth notes.

Push the valves down. Push the valves down. Play the Trum - pet Tune, yeah!

Happy Little Donkey
(Round)

American Folk Song

Moderately

55

Musical notation for 'Happy Little Donkey', starting with a treble clef, a 4/4 time signature, and a dynamic marking of *p*. The melody includes eighth notes and rests. There are three boxed sections labeled A, B, and C.

I have a don-key Hap-py is his name. I have a don-key Hap-py is his name. He is my best friend.



THEORY

Pick-up Notes

Red River Valley

Moderately

American Folk Song

56

f 3 4 1

From this val - ley they say you are go - ing; I will miss your bright
eyes and sweet smile; for they say you are tak - ing the
sun - shine that bright - ens our path - way a - while. 1 2

Musette

Moderately

Johann Sebastian Bach

57

p

Jo - hann Se - bas - tian Jo - hann Se - bas - tian Jo - hann Se - bas - tian Bach, we love him.
Born 1 - 6 - 8 - 5 died 1 - 7 - 5 - 0. He wrote the great B Mi - nor Mass.



ADVANTAGE

MEET THE INSTRUMENTS

58

The **SNARE DRUM** is made of wood or metal. It has a drum head on both the top and bottom. It also has wire snares which lightly touch the bottom drum head. It is played by striking the top head of the drum with a stick. The head vibrates and sends the vibrations through the drum to the bottom head which also vibrates, causing the snares to vibrate which produces the snare drum sound.



THEORY

Repeat within piece

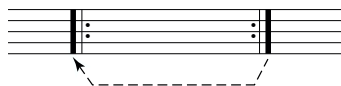

It's Raining, It's Pouring

Moderately

Traditional

59

p It's rain - ing, it's pour - ing, the old man is snore - ing. He
 went to bed and bumped his head and didn't get up till morn - ing. It's morn - ing.

When the Saints Go Marching In

Moderately

Traditional

60

f Oh, when the Saints go march - ing in, Oh, when the
 Saints go march - ing in, Yes, we'll all get up and
 join 'em, When the Saints go march - ing in.

Play Percussion

Fill in the missing word.

Sandy Feldstein & Larry Clark

61

f When I play the sold - iers come. You know me, I'm the great snare ____.

NOTES

F#

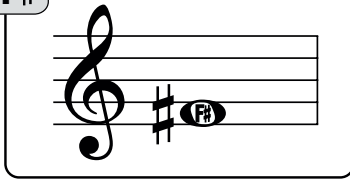

To play F#, lift up the first finger of your right hand. Your left hand fingers and fingers two and three of your right hand remain down.

SIDE VIEW

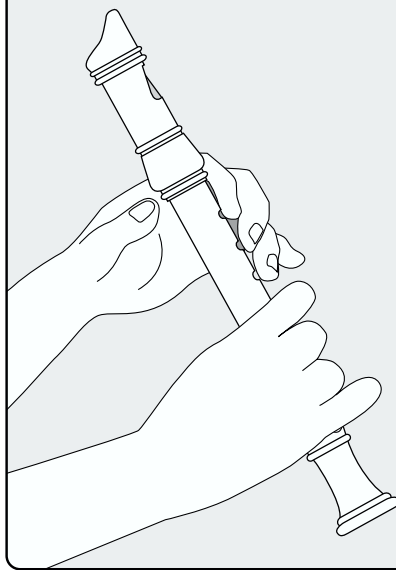

FRONT VIEW

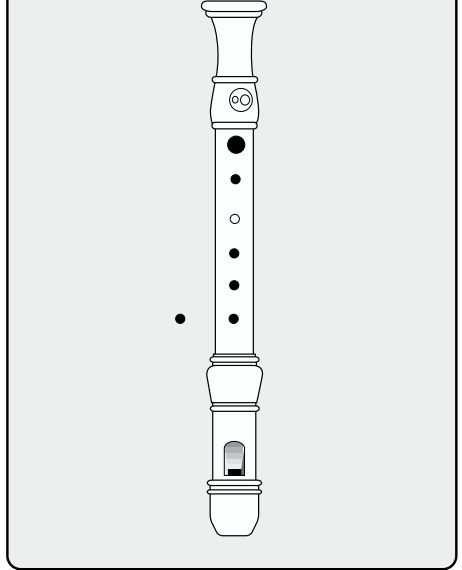

THEORY

The sharp sign (#) affects all F's that appear in the same measure.

Yankee Doodle

Moderately

Folk Song

62

f Yan - kee Doo - dle went to town a rid - ing on a po - ny,
stuck a feath - er in his hat and called it mac - a - ro - ni.

This Old Man

Moderately

Folk Song

63

f This old man, he played one, He played nick - nack on my thumb, With a
nick - nack pad - dy whack, give a dog a bone! This old man came roll - ing home.

ADVANTAGE

MEET THE INSTRUMENTS

64

The **TROMBONE**, which is made of brass, is a member of the brass family. Like the trumpet, it is played by buzzing the lips in the mouthpiece. The vibration of the lips sends vibrations into the instrument to produce the trombone sound. To play sounds (notes) that are higher or lower, you move the slide in or out.



THEORY

Key Signature

 **Key of G – one sharp (F#)**
 Play F's as F#

Twinkle, Twinkle Little Star

65

Slowly Traditional



p Twin-kle, twin-kle lit-tle star, How I won-der what you are, Up a-bove the world so high,

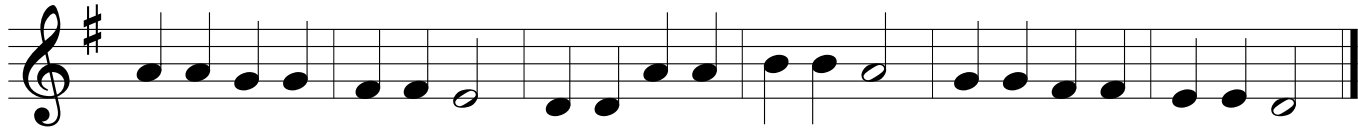

Like a dia-mond in the sky. Twin-kle, twin-kle lit-tle star, How I won-der what you are.

The Victor's March

66

Fast Traditional



f Hail! To the vic-tors, val-iant, Hail! To the con-quer-ing her-oes



Hail! Hail! To our lead-ers they are the best.



Hail! To the vic-tors, val-iant, Hail! To the con-quer-ing her-oes



Hail! Hail! To our lead-ers champ-ions of our school. Yeah!

Trombone Time

Fill in the missing word.

Sandy Feldstein & Larry Clark

67

Moderately



f The large trom-bone can not hide _____ to change its sound you use a _____.

Mary Ann

Moderately

Caribbean Folk Song

68

f All day all night, Ma - ry Ann, Down by the sea - shore sift - ing sand. All the lit - tle chil - dren love Ma - ry Ann, Down by the sea - shore sift - ing sand.

Theme from Symphony No. 1

Johannes Brahms

Slowly

69

p This theme we all know was com - posed by Jo - han - nes Brahms. This posed for the First Sym - phon - y.



ADVANTAGE

MEET THE INSTRUMENTS

70

The **VIOLIN** is made of wood with four strings attached. It is a member of the string family and plays the high notes in the orchestra. It is played by plucking the strings with the finger (like a guitar) or by drawing a bow across them. The strings vibrate to produce the violin sound. To play sounds (notes) that are higher or lower, you depress the strings at different points.

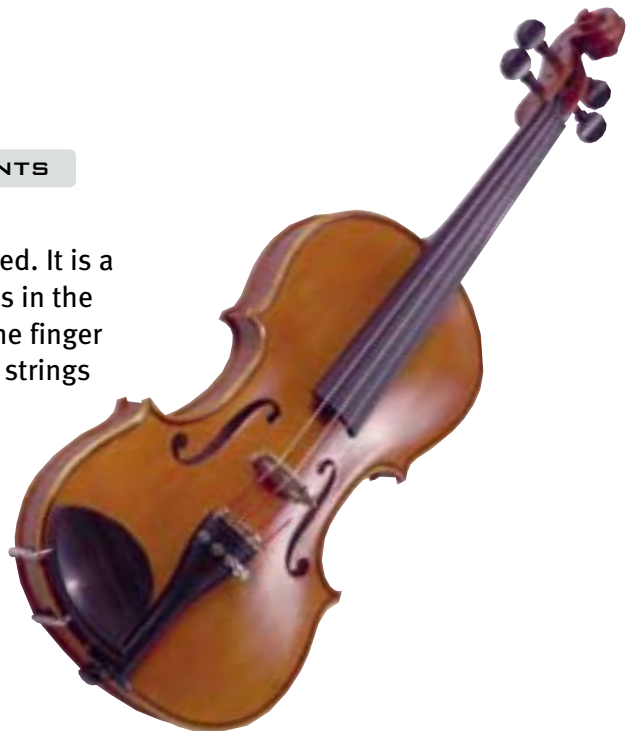

A Bicycle Built for Two

Moderately

Harry Daere

71

f Dai - sy, Dai - sy, give me your an - swer
do. I'm half cra - zy
all for the love of you. *p* It won't be a styl - ish
mar - riage; I can't af - ford a car - riage. *f* But
you'll look sweet up - on the seat of a bi - cy - cle built for two.

Fill in the missing word.

Violin Song

Slowly

Sandy Felstein & Larry Clark

72

p My string sound is high not low. To make that sound, I use a _____.

▼ ADVANTAGE
PERFORMANCE

This Little Light of Mine (Duet)

A DESCANT is a second melody or duet part played above the main melody.

Moderately
Descant

Spiritual

73

1

p

Melody

f

This lit - tle light of mine, I'm gon - na let it shine,

1a

Descant

2a

Melody

This lit - tle light of mine, I'm gon - na let it shine,

1b

Descant

2b

Melody

This lit - tle light of mine, I'm gon - na let it shine, let it

1c

Descant

2c

Melody

shine, let it shine, let it shine.

Fingering Chart

Right Hand

Left Hand

Thumb in back ○

Right Hand	Left Hand	Note
•	○ ○ ○ ○	C
•	○ ○ ○ ○	D
•	○ ○ ○ ○	E
•	○ ○ ○ ○	F
•	○ ○ ○ ○	F#
•	○ ○ ○ ○	G
•	○ ○ ○ ○	A
•	○ ○ ○ ○	B
•	○ ○ ○ ○	C
○	○ ○ ○ ○	D

**THE YAMAHA
ADVANTAGE™**
Musicianship from Day One™



Certificate of Achievement

is recognized for achieving a high standard of musicianship by
successfully completing The Yamaha Advantage™ Recorder Plus Method.

Band Director

Date



YAMAHA®



PlayTime
PRODUCTIONS, INC.